



### Description

Compressed Stabilised Earth Block made from unpolluted, undisturbed soil.

### Circularity

±80% secondary resources  
100% Closed Loop Recycling  
100% Reusable

### Manufacturer

Claesen + BC materials, in Lummen, Belgium



## Product

### Composition

- Loess loam from excavated urban sites (mineral waste stream)
- Crushed washed concrete (mineral waste stream)
- Rhine sand
- 3,85 % cement CEM III 42,5



Loess loam



Crushed washed concrete



Rhine sand



Cement

### ☰ Designation

BTCS – CL1 – RC 7 – Mv 2,0 – 13 × 9/14/19 × 29 – S 3,85 % CEM III 42,5 – XP P 13-901

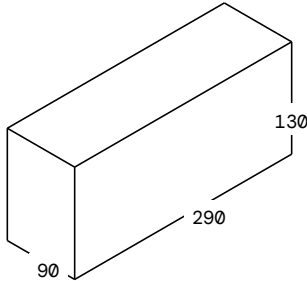

Ⓐ CEB\_90

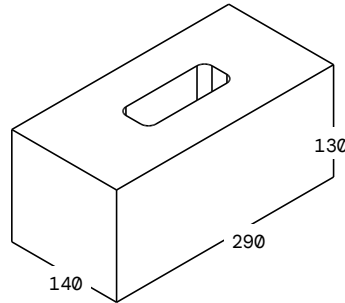

Ⓑ CEB\_140

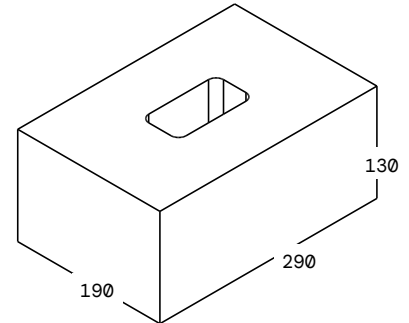

Ⓒ CEB\_190

### 📐 Physical properties of blocks

Gross/Net Density block Ⓐ CEB_90	2010/2010 kg/m <sup>3</sup>	EN772-13
Gross/Net Density block Ⓑ CEB_140	1760/2010 kg/m <sup>3</sup>	EN772-13
Gross/Net Density block Ⓒ CEB_190	1760/2010 kg/m <sup>3</sup>	EN772-13
Compressive strength ( $f_{mean}$ )	10 N/mm <sup>2</sup>	EN772-01
Tolerance Class	D2	EN771-03
Plan parallelism of the bed faces	2,0 mm	EN772-16
Flatness of Faces	0,3 mm	EN772-20
Equilibrium Moisture Content	2%	EN772-10
Initial Water Absorption	IW 2	EN772-11
Hygrometric Expansion	0,26 mm/m	EN772-14
Compressive strength category	Rc 7	XPP13-901
Static E-modulus	3000 N/mm <sup>2</sup>	DIN 18945
Application Class	CL1 (Outside masonry exposed to elements)	XPP13-901
Water vapor diffusion number $\mu$	5/10	XPP13-901
Thermal conductivity $\lambda$	1 W/m <sup>2</sup> K	XPP13-901
Fire Reaction	A1 (Non-flammable)	XPP13-901
Abrasion Category	ab 1 (best)	XPP13-901
Water Adsorption (0,5/1/3/6/24/48h)	6/10/11/29/63/93 g/m <sup>2</sup>	DIN 18945
Moisture Buffer Value	2,2 - 3	
VOC-emissions	<a href="#">VOC-free</a>	EN 16516

 Physical properties of masonry	Léém Mortar (10mm)	Léém Adhesive Mortar (2-3mm)	Bastard mortar with Léém Additive (10mm)	
Compressive Strength ( $f_{k,95\%}$ )	4,6 N/mm <sup>2</sup>	5,9 N/mm <sup>2</sup>	6,2 N/mm <sup>2</sup>	EN1052-1
Static E-modulus (mean)	3600 N/mm <sup>2</sup>	4500 N/mm <sup>2</sup>	7900 N/mm <sup>2</sup>	EN1052-1
Flexural Strength ( $f_{xk1,2}$ )	⊥ 0,20 N/mm <sup>2</sup> ∥ 0,03 N/mm <sup>2</sup>	⊥ 0,30 N/mm <sup>2</sup> ∥ 0,15 N/mm <sup>2</sup>	⊥ 0,31 N/mm <sup>2</sup> ∥ 0,14 N/mm <sup>2</sup>	EN1052-2
Initial Shear Strength ( $F_{vOk}$ )	0,02 N/mm <sup>2</sup>	0,12 N/mm <sup>2</sup>	0,22 N/mm <sup>2</sup>	EN1052-3
Bond Wrench Strength ( $F_{wk}$ )	0,02 N/mm <sup>2</sup>	0,10 N/mm <sup>2</sup>	0,08 N/mm <sup>2</sup>	EN1052-5
Airborne Sound Insulation (14cm th. without plaster)		54,3(-1,6;-4,9)dB		EN ISO 717-1
Fire Resistance (14cm th. without plaster)		(R)EI 180		NBN EN 1363-1
Specific Heat Capacity	1000 J/kgK	1000 J/kgK	1000 J/kgK	
Thermal Effusivity	15,79 m <sup>2</sup> /s	15,79 m <sup>2</sup> /s	15,79 m <sup>2</sup> /s	
Thermal Diffusivity	0,25 Wh <sup>0,5</sup> /(m <sup>2</sup> K)	0,25 Wh <sup>0,5</sup> /(m <sup>2</sup> K)	0,25 Wh <sup>0,5</sup> /(m <sup>2</sup> K)	
°T Amplitude Attenuation		TBC Q4 2025		
Phase Shifting		TBC Q4 2025		
Global Warming Pot. (GWP)(C2C) (14cm th.)		14,9 kgCO <sub>2</sub> eq/m <sup>2</sup>	20,3 kgCO <sub>2</sub> eq/m <sup>2</sup>	EN15804:A2
Environmental Impact (PEF)(C2C) (14cm th.)		1,25 mpt/m <sup>2</sup>	1,61 mpt/m <sup>2</sup>	EN15804:A2

 **Shelf life** Can be kept indefinitely when dry.

 **Packaging** Plastic wrapped pallet 120x120 cm with deposit.  
**CEB\_90** 192 pc/pallet with 1276 kg/pallet.  
**CEB\_140** 128 pc/pallet with 1190 kg/pallet.  
**CEB\_190** 96 pc/pallet with 1210 kg/pallet.

 **Usage**

**CEB\_90 in a halfblock wall**  
 1 pallet = 8,06 m<sup>2</sup> with 10mm joints or 7,48 m<sup>2</sup> with 3mm joints  
 1 m<sup>2</sup> = 23,81 pc with 10mm joints or 25,66 pc with 3mm joints

**CEB\_140 in a halfblock wall**  
 1 pallet = 5,38 m<sup>2</sup> with 10mm joints or 4,99 m<sup>2</sup> with 3mm joints  
 1 m<sup>2</sup> = 23,81 pc with 10mm joints or 25,66 pc with 3mm joints

**CEB\_190 in a halfblock wall**  
 1 pallet = 4,03 m<sup>2</sup> with 10mm joints or 3,74 m<sup>2</sup> with 3mm joints  
 1 m<sup>2</sup> = 23,81 pc with 10mm joints or 25,66 pc with 3mm joints

## Field of application

For masonry protected from the elements. Suitable for damp rooms, do not apply in areas of direct contact with water. See our Earth Block Guide for conception and execution guidelines.  
 Suitable for load-bearing walls if Eurocode 6 is followed.







## Characteristics

---

Circular material in origin: Valorization of a "waste" stream  
 Circular material in destination: infinitely reusable  
 CO2 neutral: no combustion required to produce the building material  
 Made of undisturbed, unpolluted soil  
 Moisture and heat regulating  
 Vapor-open  
 Anti-static  
 Reduces acoustic transmission and reverberation  
 Colorstable

## Execution

---

 <b>Storage</b>	Store in a dry place, lifted from the ground, on a flat surface, move without jarring.
 <b>Conditions</b>	Upon execution, the temperature of the air and substrate should be minimum 5°C.
 <b>Application</b>	The rules of craftsmanship are carefully followed when mortaring the earth blocks. Please check Earth Block Guide by Léém for conception and execution guidelines. Mix minimum 6 pallets when masoning, prewet blocks before laying, use a rubber hammer to put in place, protect fresh masonry walls from rain.
 <b>Drying time</b>	Under normal conditions (20°C and 60% relative humidity), the masonry wall will dry in 14 days.
 <b>Tools</b>	Rubber hammer, Léém Adhesive Mortar Spreader Box/Trowel, standard masonry tools.
 <b>Disposal</b>	Before disposing of Léém Compressed Blocks, remember to recover and reuse them, as they can be dismantled easily. There is a take-back program available, contact us for more information. When used correctly, Léém Compressed Blocks are harmless to humans and the environment. Waste can be disposed of as non-hazardous inert waste.

## Legislation

---

 <b>Conformity</b>	Complies with Brussels Soil Ordinance and Decree March 29, 2018. Complies with Flemish Soil Decree and its implementation rules (VLAREMA and VLAREBO). Tested on 40+ parameters of pollution: Non-polluted resources: No PCB, asbestos, PFC, lead, flame retardants, phthalates, isocyanates, PFAS, ...
---	---

### Disclaimer

---

The information in this product description has been compiled with the greatest care. Compensation claims, unless they result from factory mixing errors, are excluded. With each new edition of the product information, the validity of the previous edition expires.